

413FW. The underground mining engine.

93-322 hp at 2300 rpm



These are the characteristics of the 413FW:

Air-cooled four stroke 6-, 8-, 10- and 12-cylinder in v-configuration.

12-cylinder also with turbocharging.

DEUTZ-two-stage combustion.

Extremely compact design.

High torque at low speed.

Robust and especially suited for use under extreme conditions.

Customized component system with many different peripheral parts.

Your benefits:

- ▶ Fast response to load changes.
- ▶ Low operating costs thanks to lower fuel consumption, low specific ventilation requirements and long maintenance intervals with reduced maintenance requirements.
- ▶ Operation advantages due to compact design and low power-to-weight ratio.
- ▶ Robust engine design ensures high operating safety.

► Technical data

Engine type		F6L413FW	F8L413FW	F10L413FW	F12L413FW	BF12L413FW
Number of cylinder		6	8	10	12	12
Bore/stroke	mm	125/130	125/130	125/130	125/130	125/130
Displacement	l	9.572	12.763	15.953	19.144	19.144
Compression ratio		19.5	19.5	19.5	19.5	19.5
Max. rated speed	rpm	2300	2300	2300	2300	2300
Mean piston speed	m/s	9.96	9.96	9.96	9.96	996

Power ratings for underground mining engines

Power ratings ¹⁾	hp	137	182	228	274	322
at speed ²⁾	rpm	2300	2300	2300	2300	2300
Mean effective pressure	bar	5,56	5,56	5,56	5,56	6,54
Max. torque	Nm	500	665	830	995	1250
at speed	rpm	1500	1500	1500	1500	1500
Minimum idle speed	rpm	600	600	600	600	600
Spec. fuel consumption ³⁾	g/kWh	276	276	276	276	276
Weight ⁴⁾	kg	660	830	990	1120	1300

► Dimensions

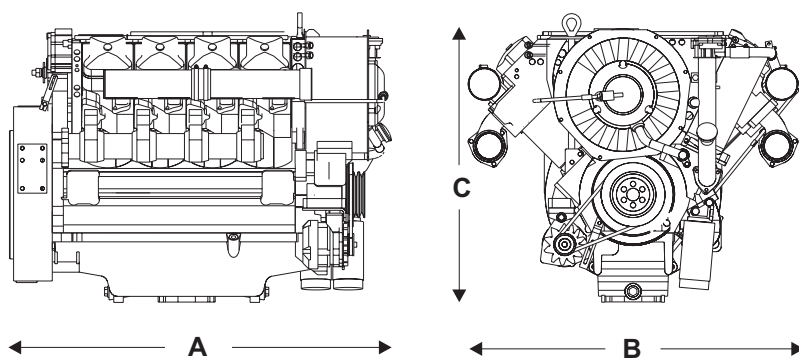

Engine		Length	Width	Hight
F6L413FW	mm	915	1038	860
F8L413FW	mm	1080	1038	860
F10L413FW	mm	1283	1038	999
F12L413FW	mm	1448	1038	1007
BF12L413FW	mm	1380	1192	1112

- 1) Power ratings without deduction fan power requirements, incl. cooling system. Ratings as per ISO 3046.
- 2) Power ratings for non-mentioned speeds upon request.
- 3) At optimal operating point. Specific fuel consumption based on diesel fuel with a specific gravity of 0,835 kg/dm³ at 15°C.
- 4) Acc. to DIN 70020, Part 7A. Without starter motor/alternator, radiator and liquids, however with flywheel and flywheel housing.



DEUTZ AG
 Deutz-Mülheimer Str. 147-149
 D-51057 Köln
 Tel.: ++49 (0) 221-822-2510
 Fax: ++49 (0) 221-822-2529
 Internet: <http://www.deutz.de>